

AWS10

SECTORS:



CHARACTERISTICS:

- Unbalanced.
- System attached to the shaft by allen screws.
- Not dependent on the rotation direction.

OPERATING LIMITS:

$d_f = 14$ to 150 mm $p = 10$ kg/cm²
 $v = 20$ m/s $t = -15$ to $+200^\circ\text{C}^*$

(* The temperature resistance depends on the material of the secondary seals used.

The operating limits are defined by the PV factor which is determined for the sealing system characteristics and those of the application.

DESCRIPTION:

Recommended for working with sticky fluids and fluids laden with particles and fibres. Unlike the multispring models, the wave spring model cannot be blocked or obstructed and its open leaf design produces a self-cleaning effect. Standard L9 type stationary part. Seal compliant with standard EN 12756 (KU). Available with a pumping ring on the casing to reduce the temperature between the contact surfaces and facilitate the barrier fluid movement in the case of double mounting (AWS10-F).

COMPONENTS:

- 1 Rotating contact surface
- 2 Stationary contact surface
- 3 O-rings
- 3a O-rings
- 4 Springs
- 5 Metal frame
- 5a Set screws
- 5b Ring

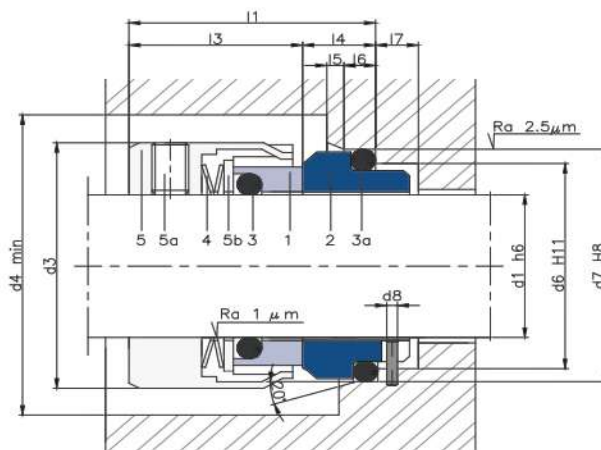
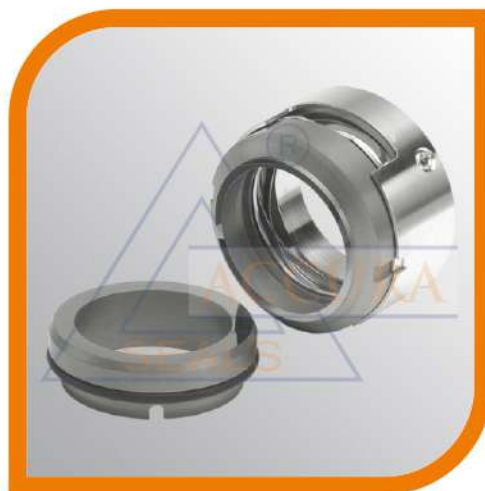

Tolerance: $l_1, d_1, 14..25$ mm ± 1.0 ; $28..63$ mm ± 1.5 ; > 65 mm ± 2.0

DIMENSIONS CHART Dimensions in mm

Shaft mm	Rotary part			Stationary part							Total length l_1
	d_3	d_4	l_3	d_6	d_7	d_8	l_4	l_5	l_6	l_7	
14	25	30	25.0	21	25	3	10.0	1.5	4	8.5	35.0
16	27	32	25.0	23	27	3	10.0	1.5	4	8.5	35.0
18	33	38	26.0	27	33	3	11.5	2.0	4	9.0	37.5
20	35	40	26.0	29	35	3	11.5	2.0	5	9.0	37.5
22	37	42	26.0	31	37	3	11.5	2.0	5	9.0	37.5
24	39	44	28.5	33	39	3	11.5	2.0	5	9.0	40.0
25	40	45	28.5	34	40	3	11.5	2.0	5	9.0	40.0
28	43	48	31.0	37	43	3	11.5	2.0	5	9.0	42.5
30	45	50	31.0	39	45	3	11.5	2.0	5	9.0	42.5
32	47	52	31.0	42	48	3	11.5	2.0	5	9.0	42.5
33	48	53	31.0	42	48	3	11.5	2.0	5	9.0	42.5
35	50	55	31.0	44	50	3	11.5	2.0	5	9.0	42.5
38	55	60	31.0	49	56	4	14.0	2.0	6	9.0	45.0
40	57	62	31.0	51	58	4	14.0	2.0	6	9.0	45.0
43	60	65	31.0	54	61	4	14.0	2.0	6	9.0	45.0
45	62	67	31.0	56	63	4	14.0	2.0	6	9.0	45.0
48	65	70	31.0	59	66	4	14.0	2.0	6	9.0	45.0
50	67	72	32.5	62	70	4	15.0	2.5	6	9.0	47.5
53	70	75	32.5	65	73	4	15.0	2.5	6	9.0	47.5
55	72	77	32.5	67	75	4	15.0	2.5	6	9.0	47.5
58	79	84	37.5	70	78	4	15.0	2.5	6	9.0	52.5
60	81	86	37.5	72	80	4	15.0	2.5	6	9.0	52.5
63	84	89	37.5	75	83	4	15.0	2.5	6	9.0	52.5
65	86	91	37.5	77	85	4	15.0	2.5	6	9.0	52.5
68	89	94	34.5	81	90	4	18.0	2.5	7	9.0	52.5
70	91	96	42.0	83	92	4	18.0	2.5	7	9.0	60.0
75	99	104	42.0	88	97	4	18.0	2.5	7	9.0	60.0
80	104	109	41.8	95	105	4	18.2	3.0	7	9.0	60.0
85	109	114	41.8	100	110	4	18.2	3.0	7	9.0	60.0
90	114	119	46.8	105	115	4	18.2	3.0	7	9.0	65.0
95	119	124	47.8	110	120	4	17.2	3.0	7	9.0	65.0
100	124	129	47.8	115	125	4	17.2	3.0	7	9.0	65.0

Dimensions subject to changes or modifications.

Shaft mm	Rotary part			Stationary part							Total length l_1
	d_3	d_4	l_3	d_6	d_7	d_8	l_4	l_5	l_6	l_7	
105	138	143	47	122.2	134.3	5	20	2	10	--	67
110	143	148	47	128.2	140.3	5	20	2	10	--	67
115	148	153	47	136.2	148.3	5	20	2	10	--	67
120	153	158	47	138.2	150.3	5	20	2	10	--	67
125	158	163	47	142.2	154.3	5	20	2	10	--	67
130	163	168	47	146.2	158.3	5	20	2	10	--	67
135	168	173	47	152.2	164.3	5	20	2	10	--	67
140	173	178	47	156.2	168.3	5	20	2	10	--	67
145	178	183	47	161.2	173.3	5	20	2	10	--	67
150	183	189	47	168.2	180.3	5	22	2	10	--	69

* Multispring design manufacture for $d_1 > 100$ mm.